

SOLIN AG

Technologien verbinden

*Improving Testing Productivity
through the use of
Test Automation*

Michael Cujé @ Real-Time 2010, June, 28th



Improving Testing Productivity through the use of Test Automation

1

Testing as part of the development process

2

Test Automation equipment

3

Testing measures

4

Advantages Test Automation

Product development example

Elevator drive

Application



Components



Symbols

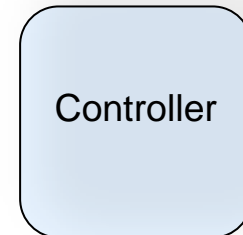
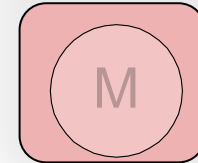

V-model

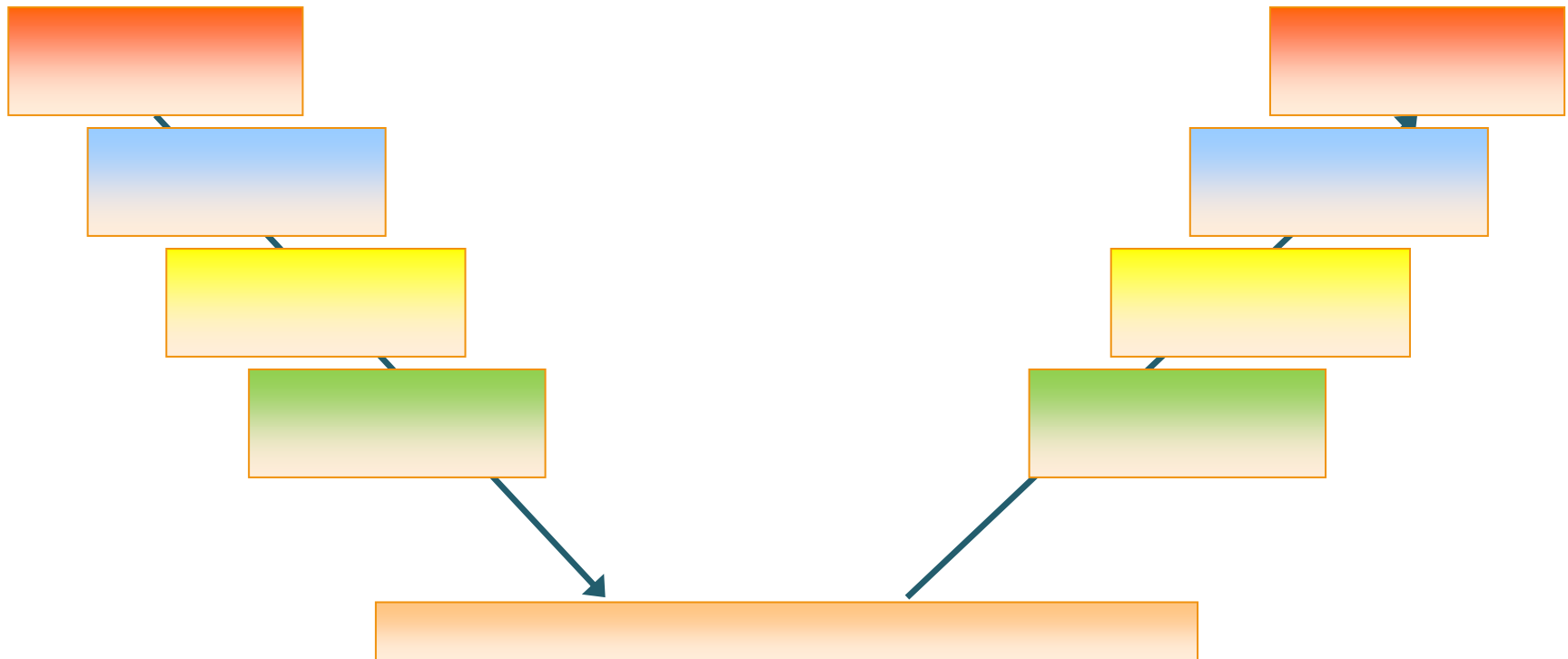



Customer requirements specification

- max. speed of engine
- needed power
- power connection
- interface
- ...



Mapping of all requirements to a functional diagram

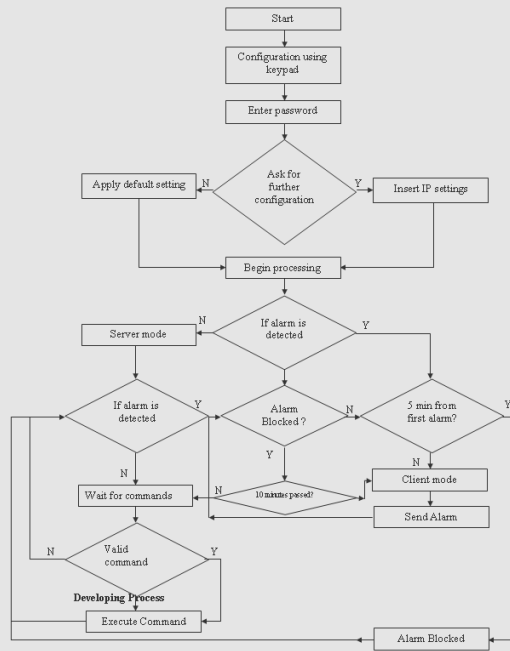
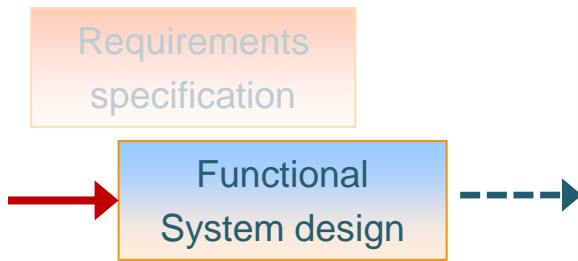

Design of the system architecture

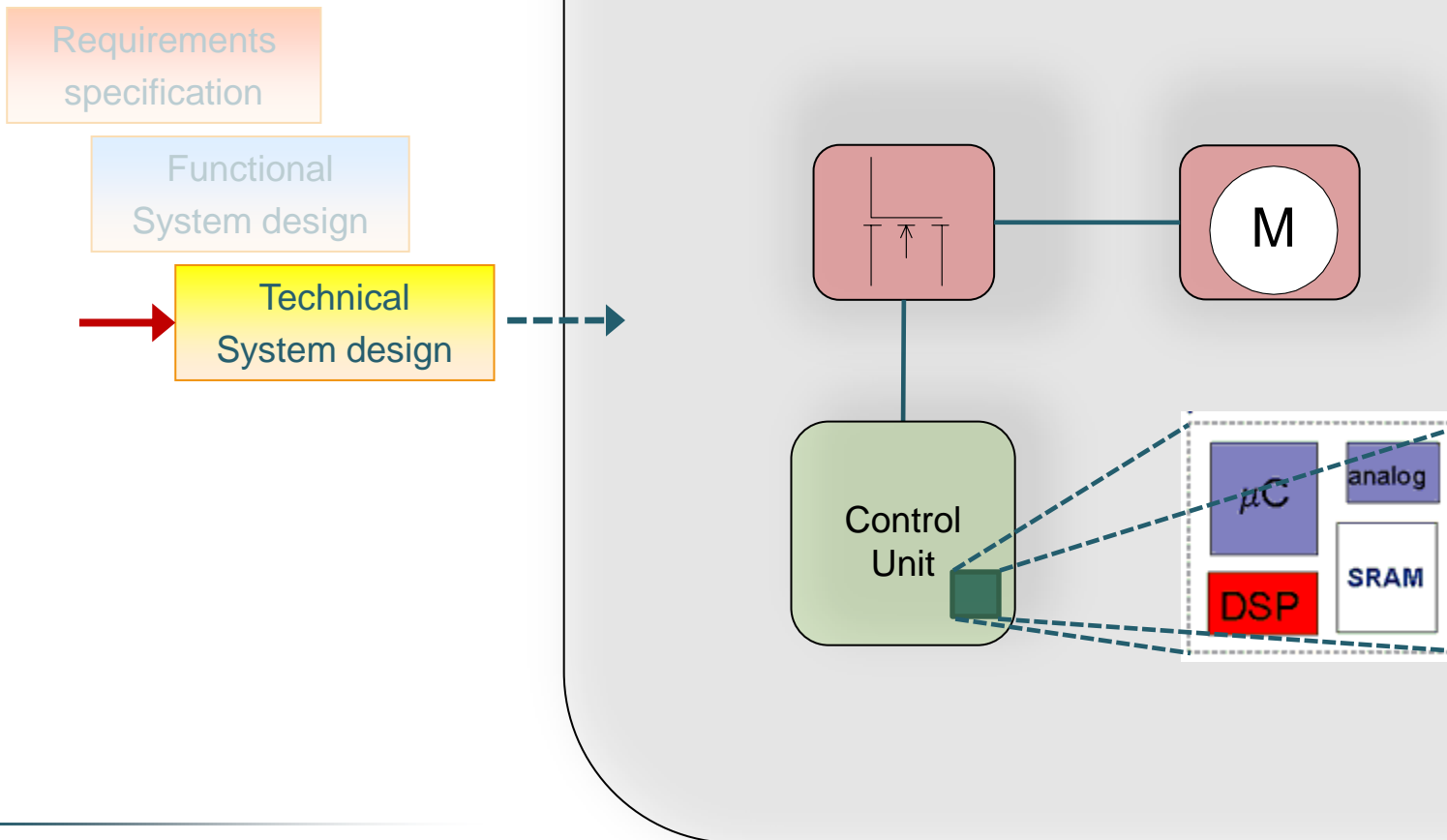

Components specification

- function
- behaviour
- interfaces

Requirements
specification

Functional
System design

Technical
System design

Components
specification

Control
Unit

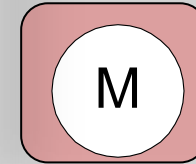
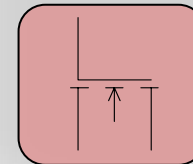

Product Development with V-Model

DESIGN → IMPLEMENTATION → TEST

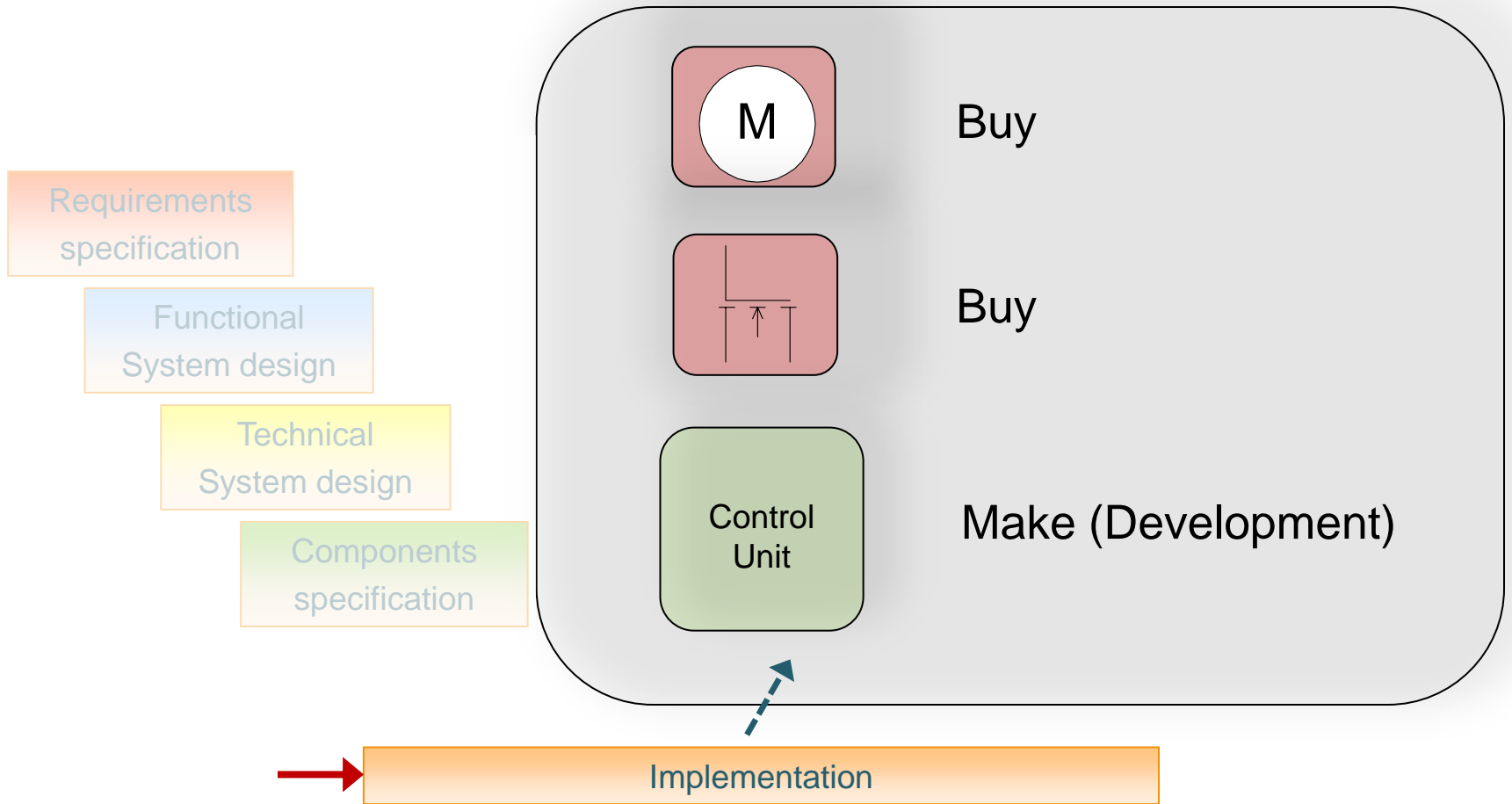

Product Development with V-Model

DESIGN → IMPLEMENTATION → TEST

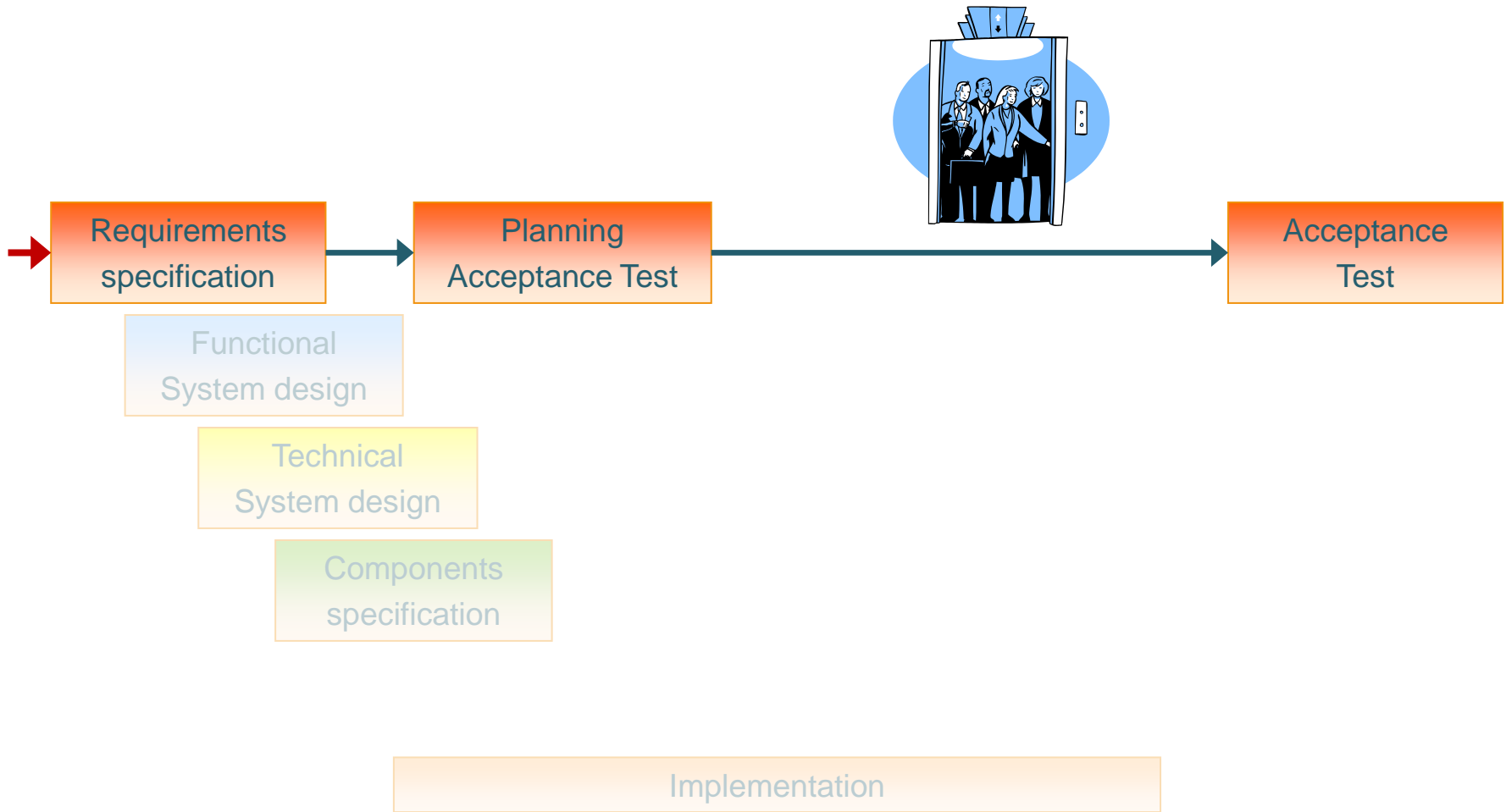

Product Development with V-Model

DESIGN → IMPLEMENTATION → TEST

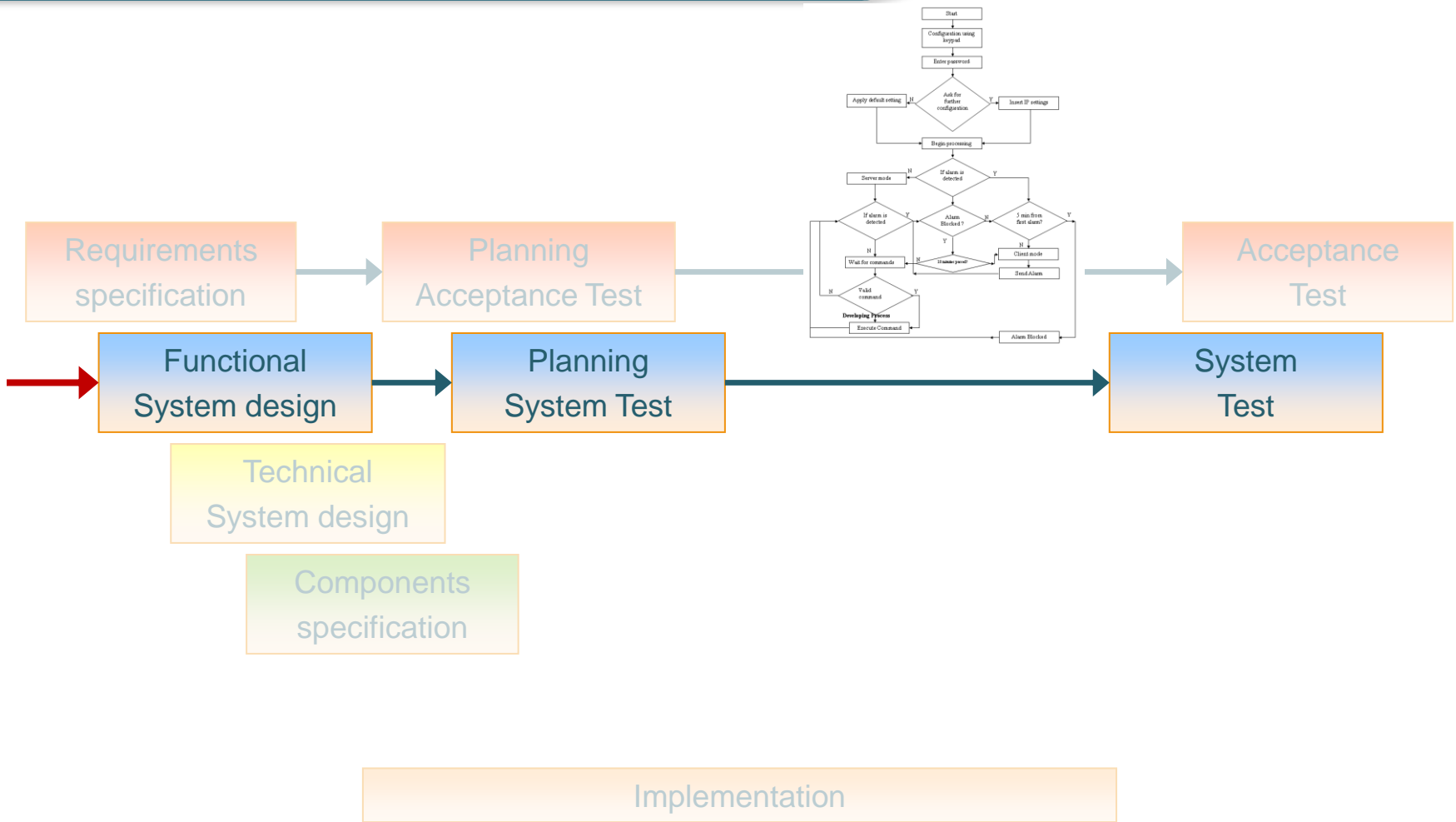

Product Development with V-Model

DESIGN → IMPLEMENTATION → TEST

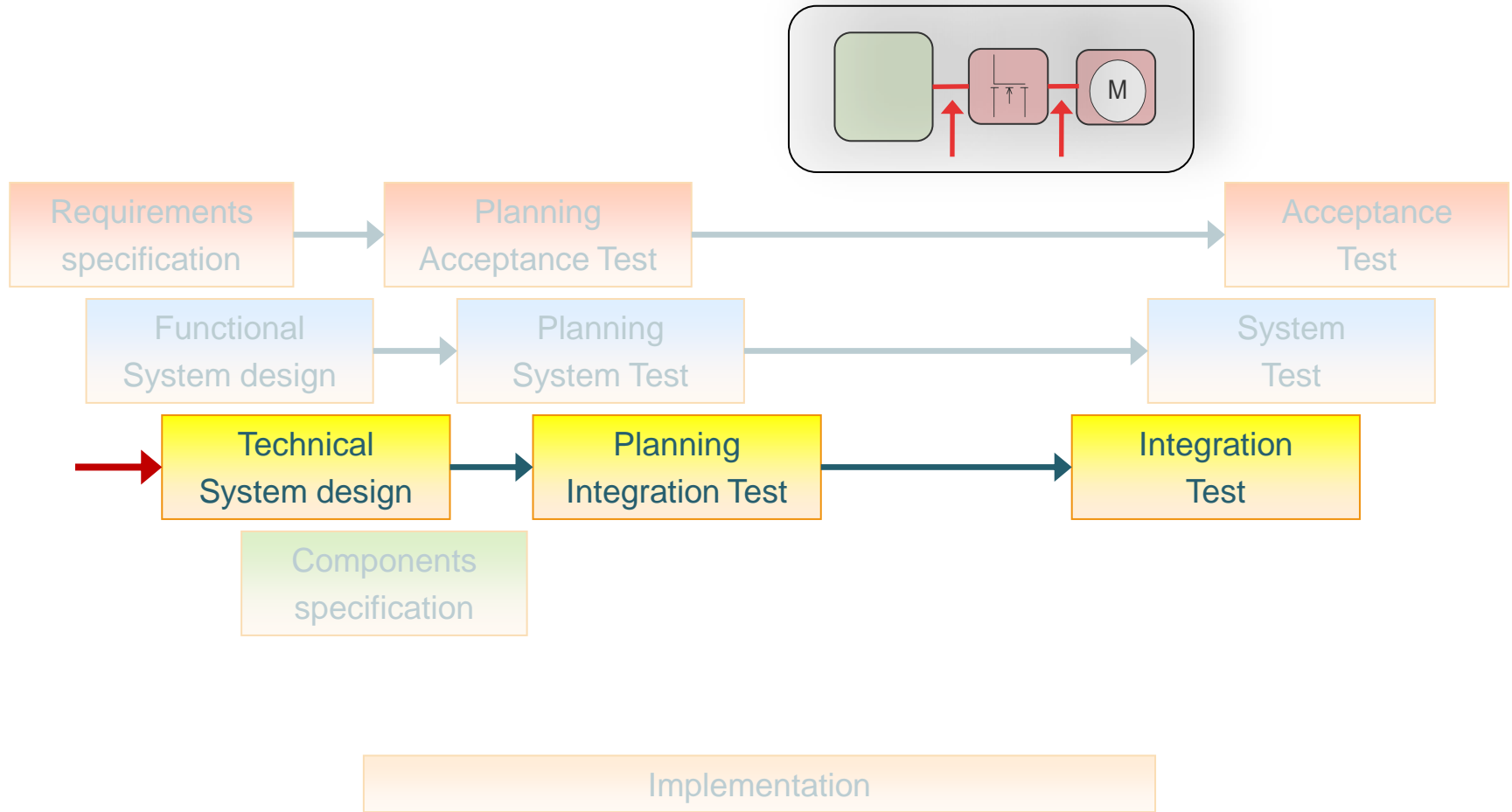

Product Development with V-Model

DESIGN → IMPLEMENTATION → TEST

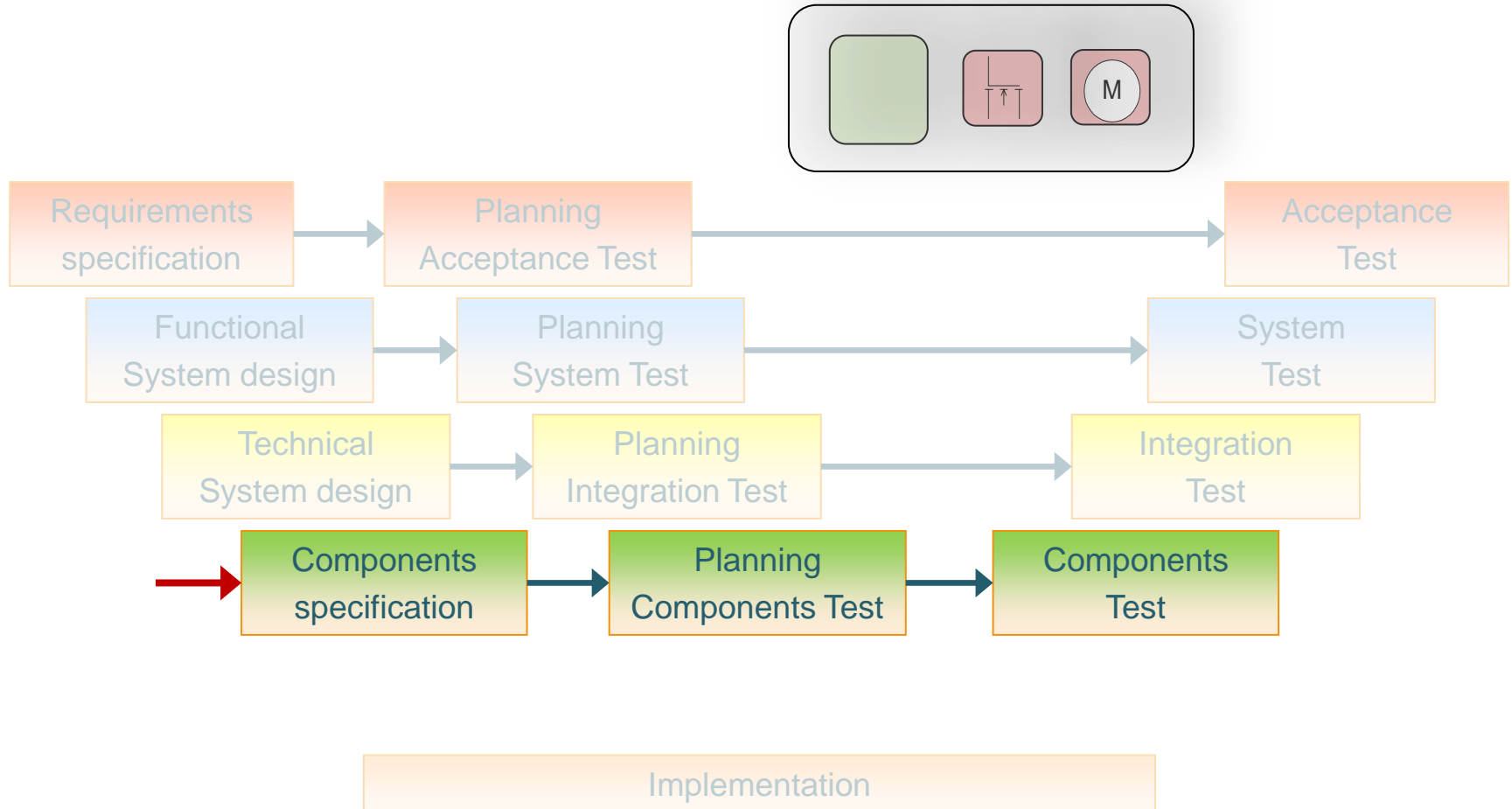

Product Development with V-Model

DESIGN → IMPLEMENTATION → TEST

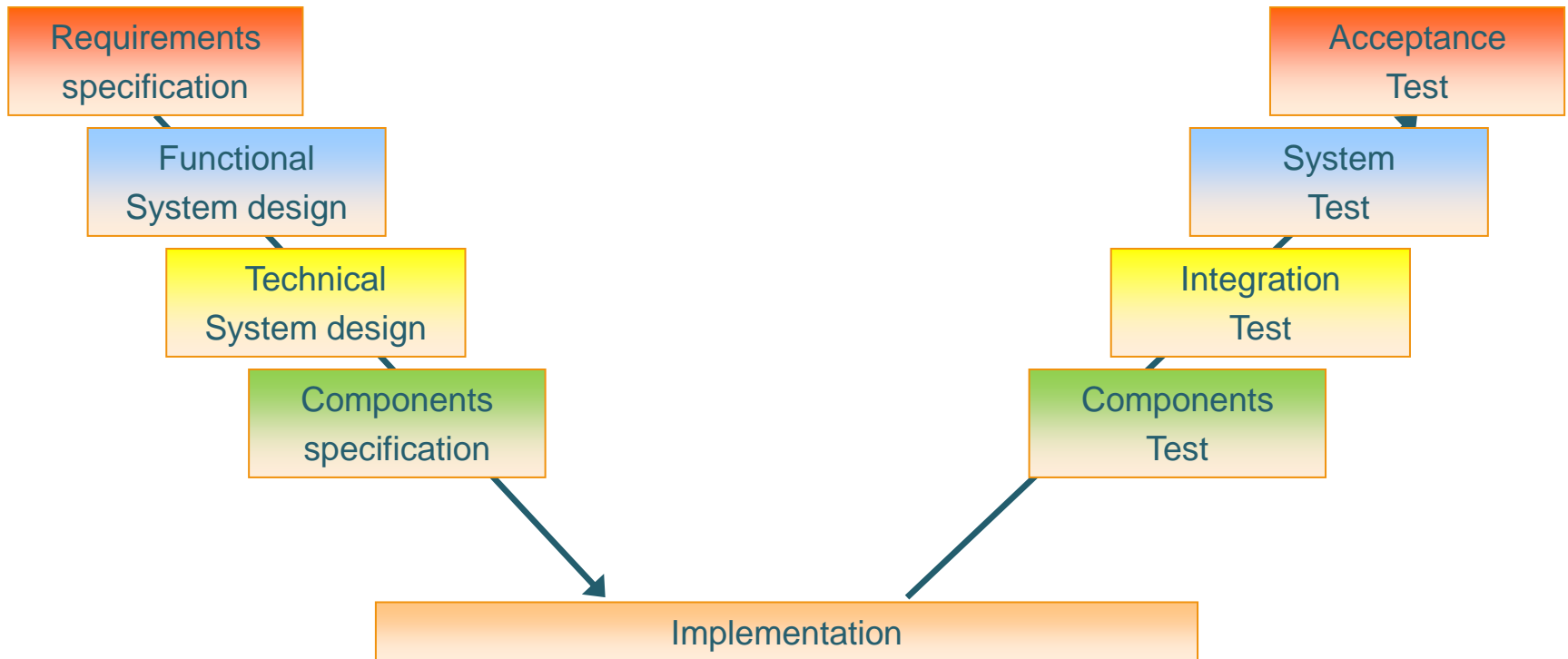

Product validation	Diversity of variants	Measure of quality	Preventing defects	Unveiling defects	Tests (V-model)
X		X			Acceptance Test
	X	X	(X)	X	System Test
	X		X	X	Integration Test
			X	X	Components Test

Typical testing types

- **Manual tests**
- **White box tests**
- **Black box tests**
- **Regression tests**
- **Stress tests**

Product validation	Diversity of variants	Measure of quality	Preventing defects	Unveiling defects	Tests (V-model)
Manual test		Stress test			Acceptance Test
	Regression	Stress test	Regression	Regression	System Test
	Regression Blackbox		Regression Blackbox	Regression Blackbox	Integration Test
			Regression Whitebox	Regression Whitebox	Components Test

Test case

- Set relay nr. **5**
- Start simulation
- Set speed to **100** rpm
- Check current nr. **4**



Setting steps

Verifying step

Test case
<ul style="list-style-type: none"> ■ Set relay nr. 5 ■ Start simulation ■ Set speed to 100 rpm ■ Check current nr. 4

Test parameter set 1	Test parameter set 2
5	4
100	120
4	3

Test case set
<ul style="list-style-type: none"> ■ Test case 1 ■ Test case 2 ■ Test case ...

Set 1	Set 2
X	
X	X
	X

Product validation	Diversity of variants	Measure of product quality	Preventing defects	Unveiling defects	Tests (V-model)
		TA			Acceptance Test
	TA	TA	TA	TA	System Test
	TA HIL		TA HIL	TA HIL	Integration Test
			TA HIL	TA HIL	Components Test



Test Automation



Hardware In the Loop

Improving Testing Productivity through the use of Test Automation

1 Testing as part of the development process

2 Test Automation equipment

3 Testing measures

4 Advantages Test Automation

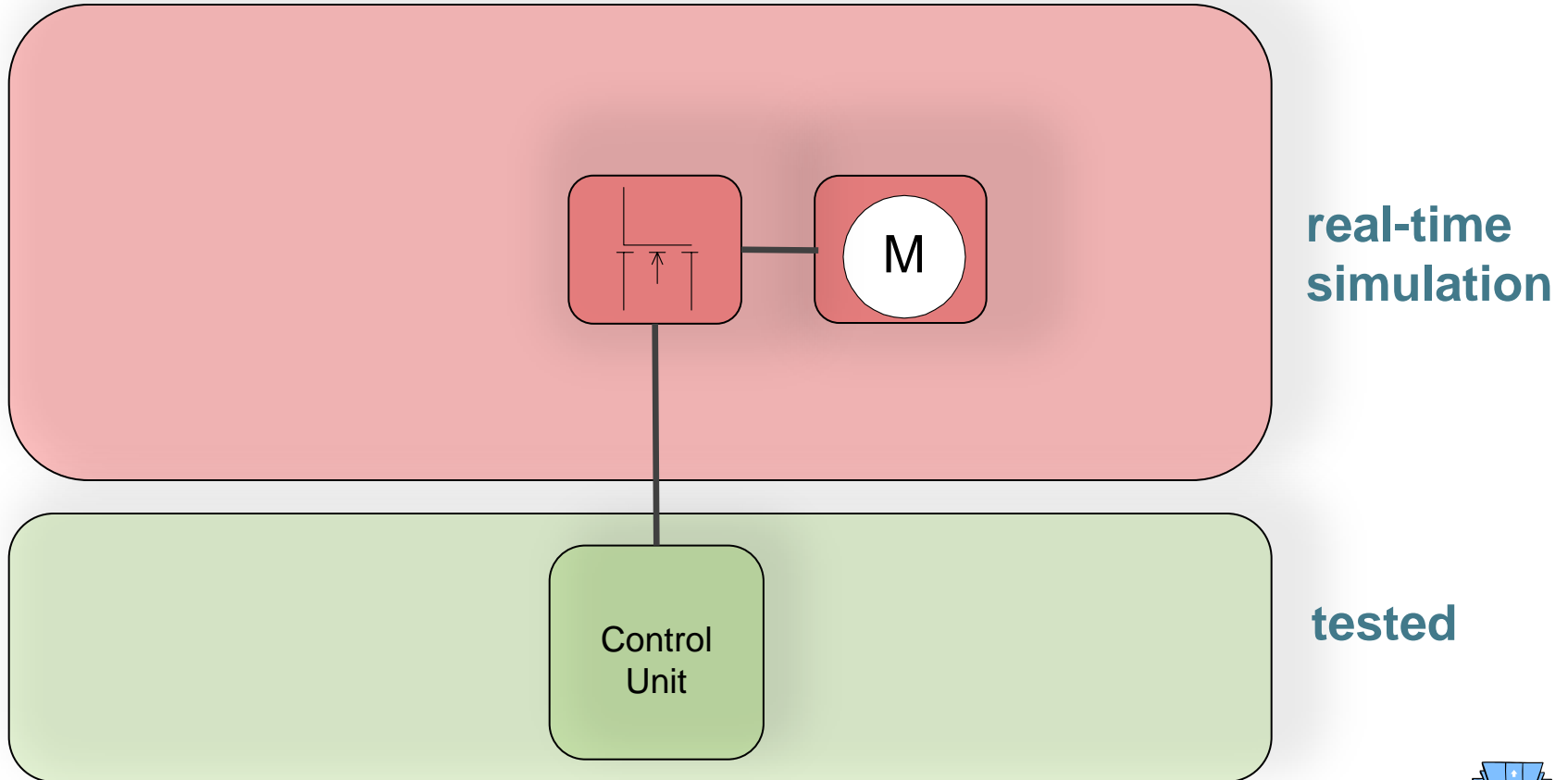

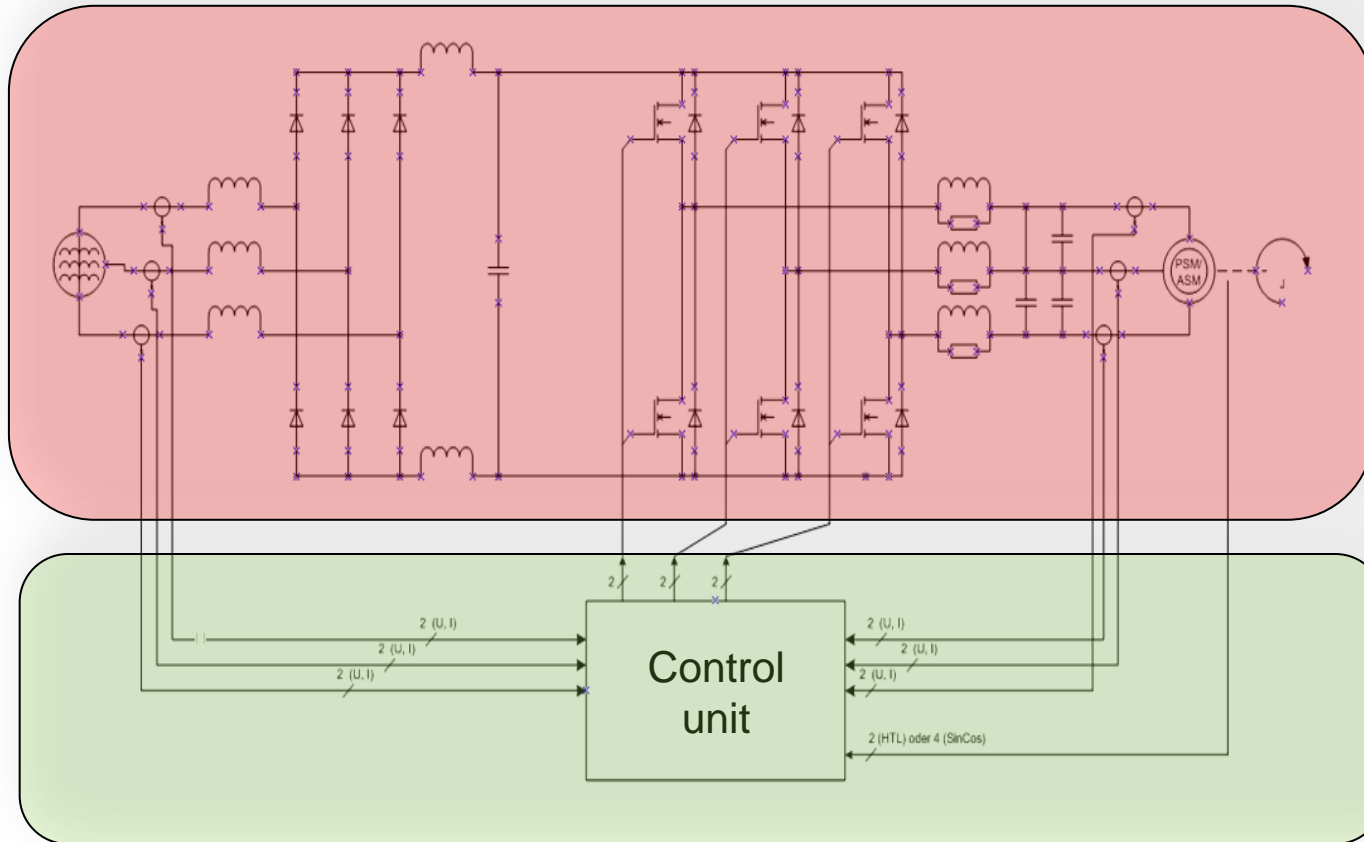

**real-time
simulation**

tested

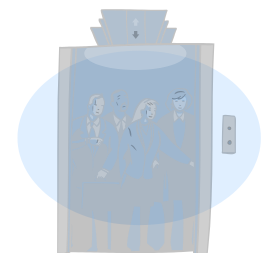

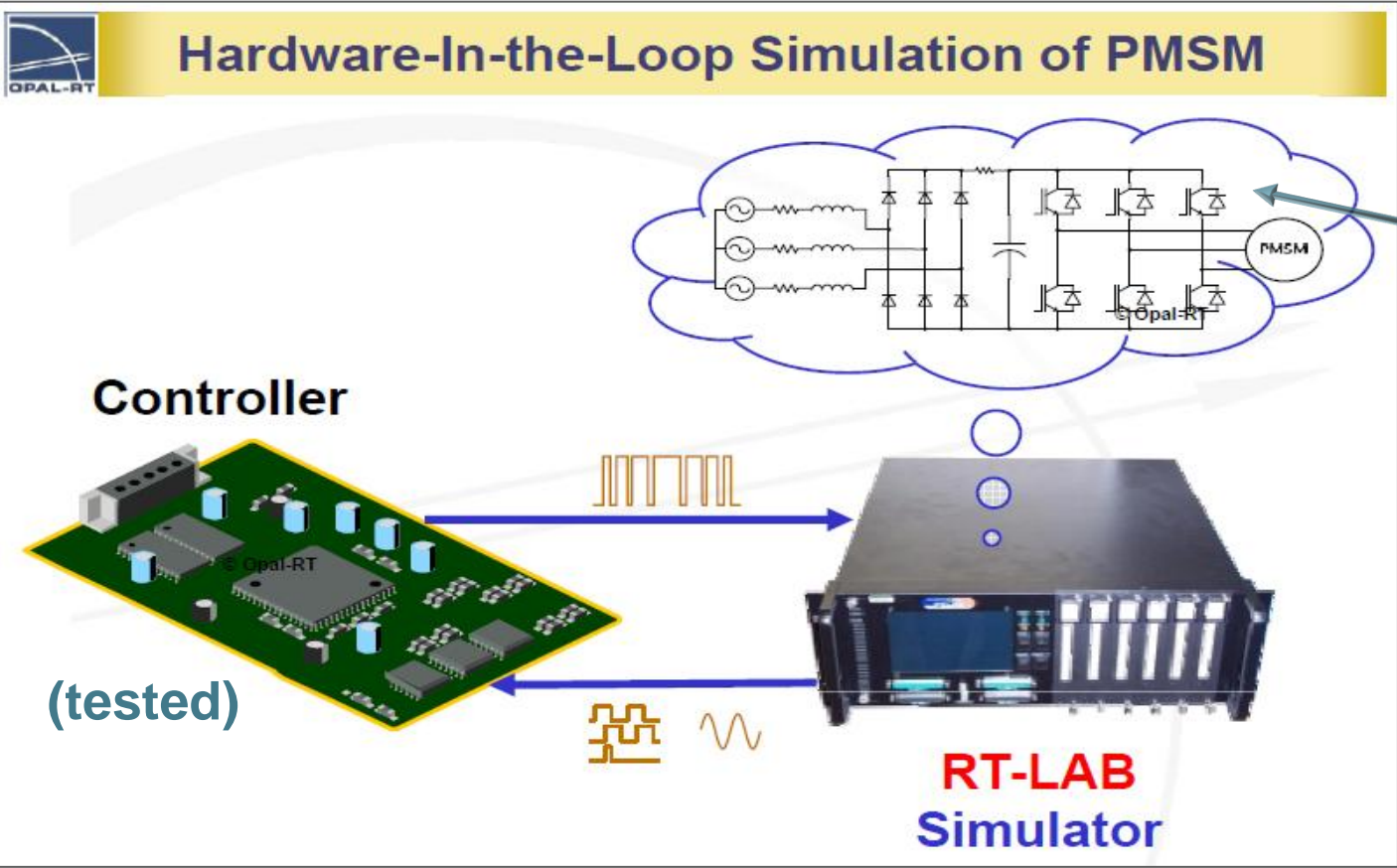

real-time simulation



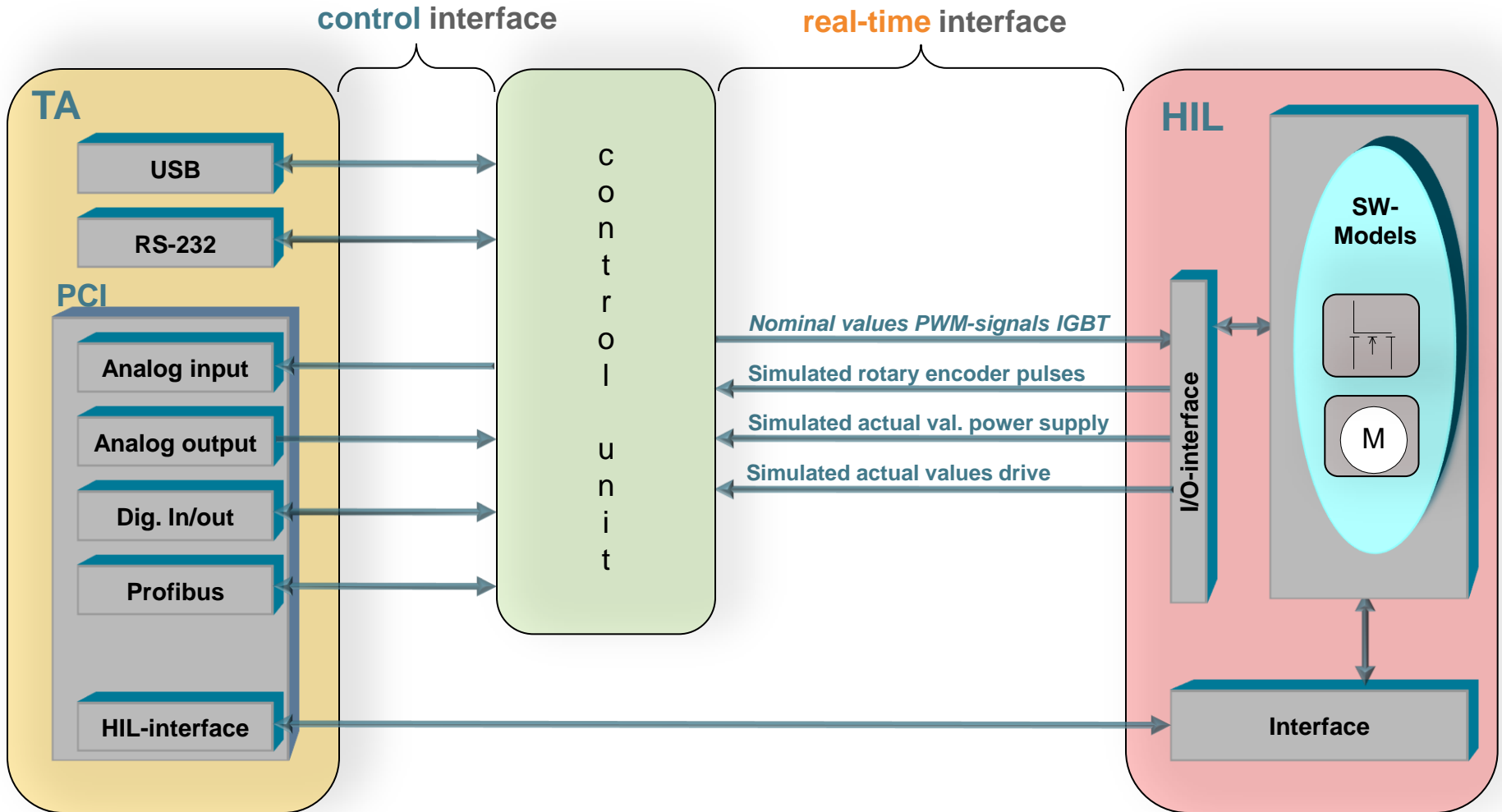

TESTING equipment : Test Automation SW structure

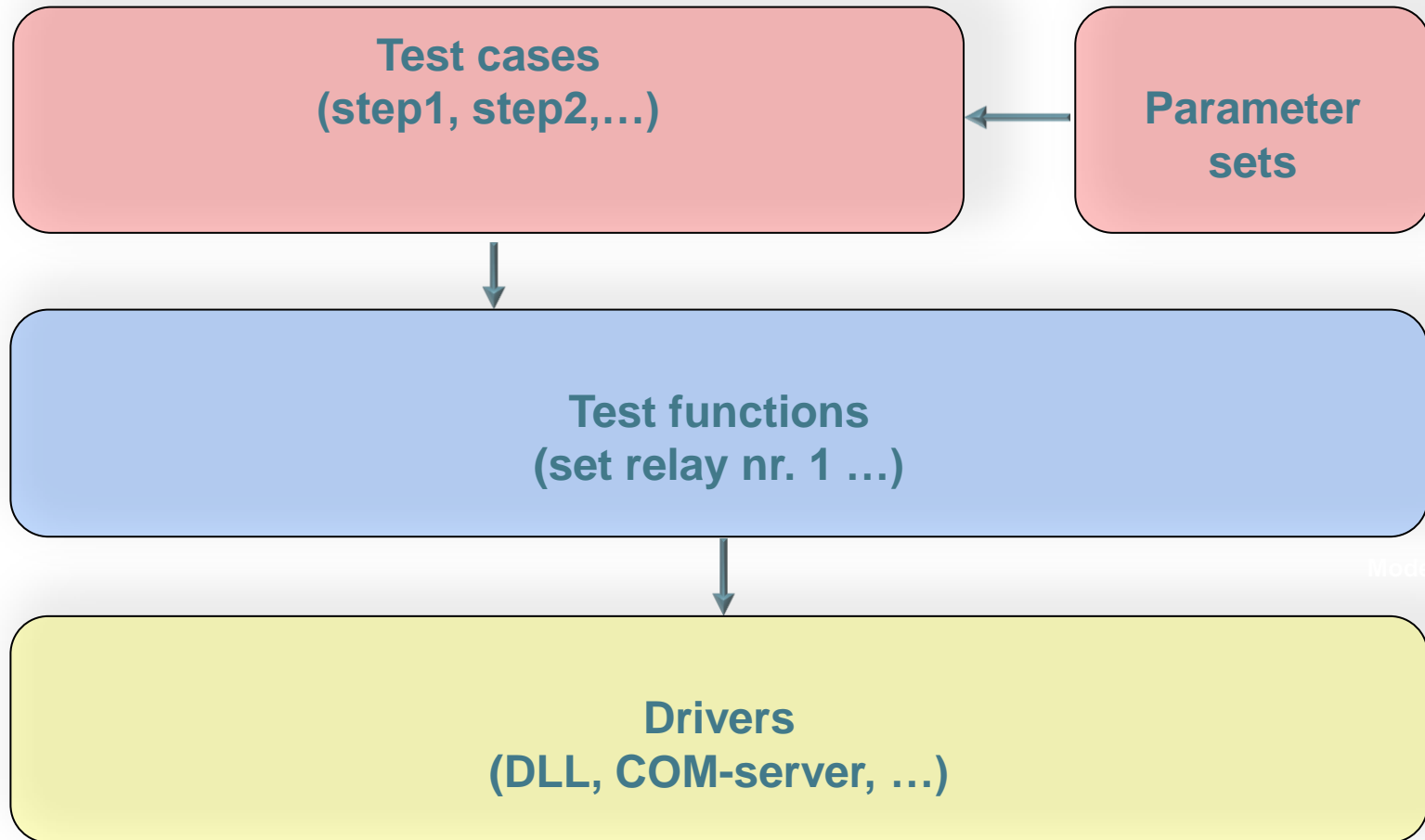

TESTING equipment : Test Automation SW structure

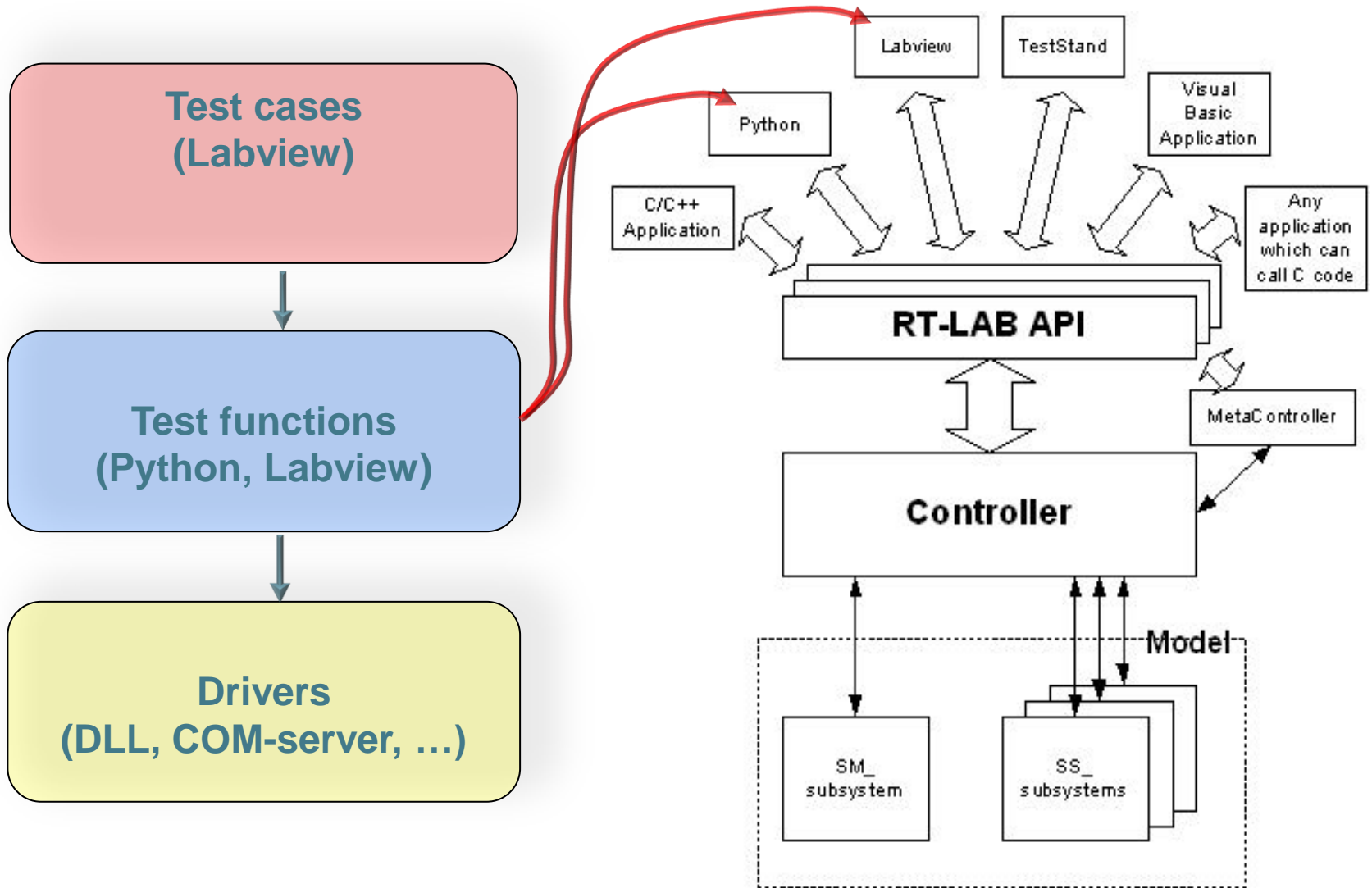

Improving Testing Productivity through the use of Test Automation

1 Testing as part of the development process

2 Test Automation equipment

3 Testing measures

4 Advantages Test Automation

Product validation	Diversity of variants	Measure of product quality	Preventing defects	Unveiling defects	Tests (V-model)
X		TA			Acceptance Test
	TA	TA	TA	TA	System Test
	TA, HIL		TA, HIL	TA, HIL	Integration Test
			TA, HIL	TA, HIL	Components Test



Test Automation



Hardware In the Loop

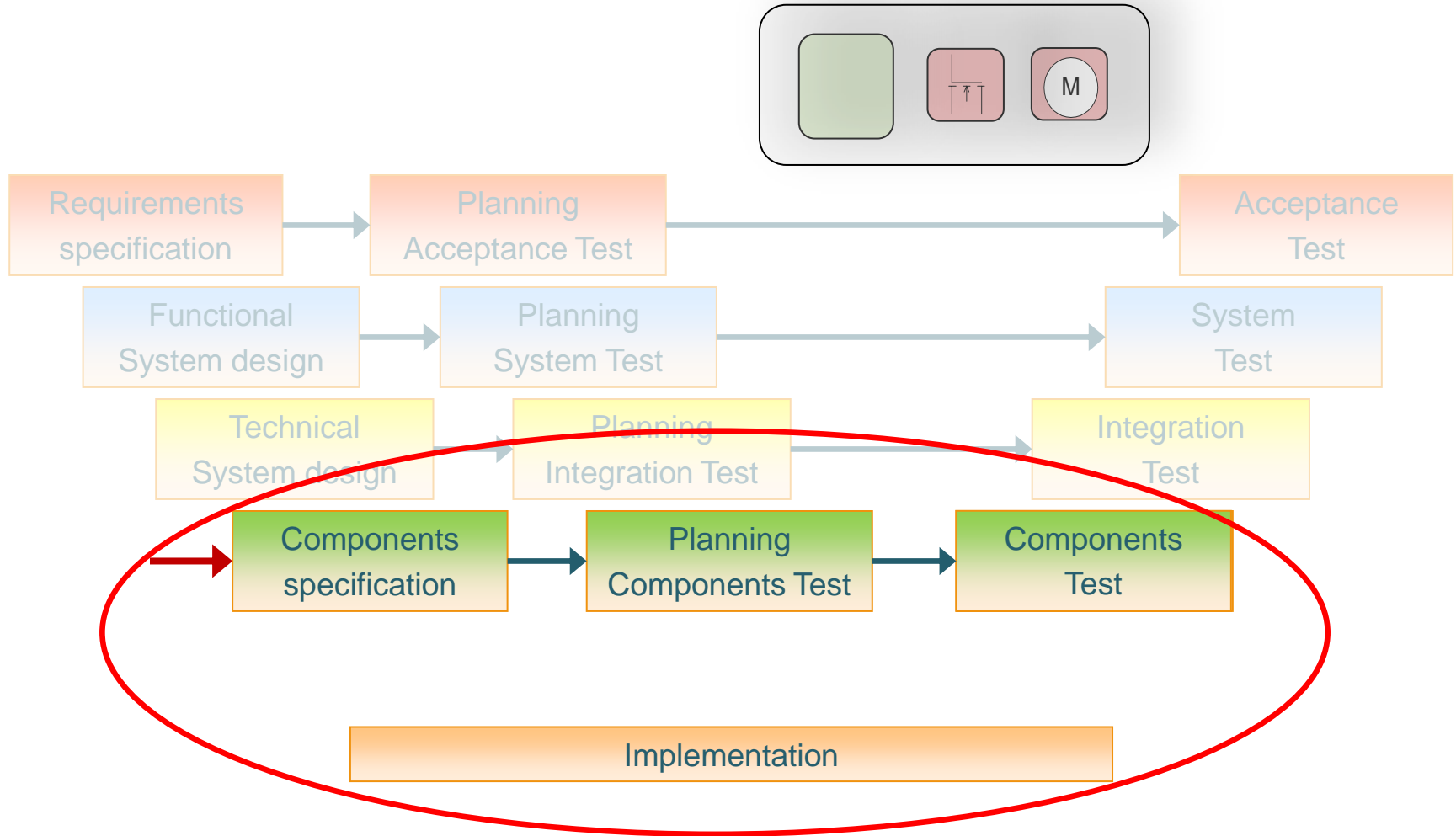

Components Test

Sequential incremental development model

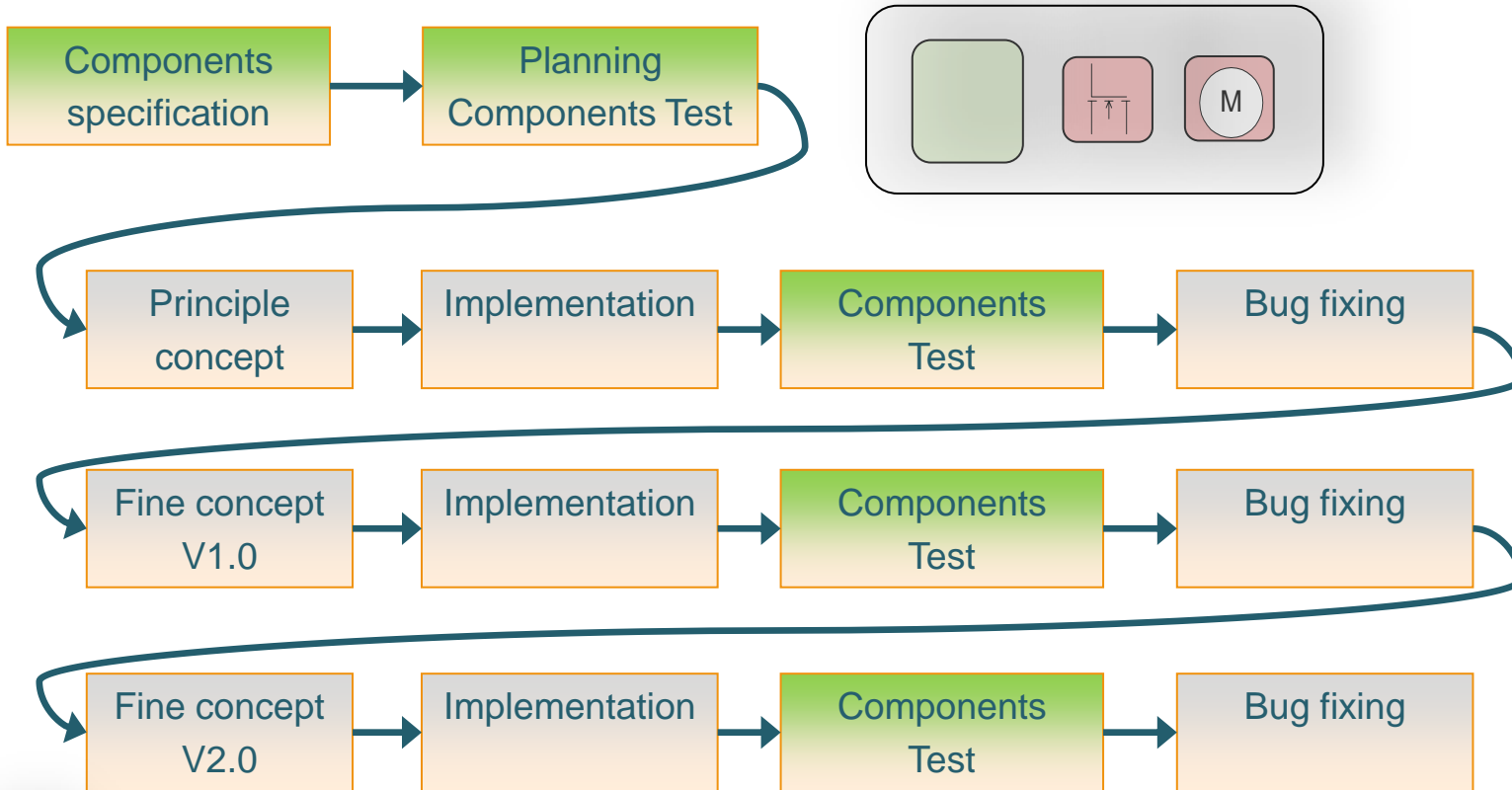

HIL

HIL → early components testing (HW / SW codesign)

TA

TA → early defect tracking through first regression tests

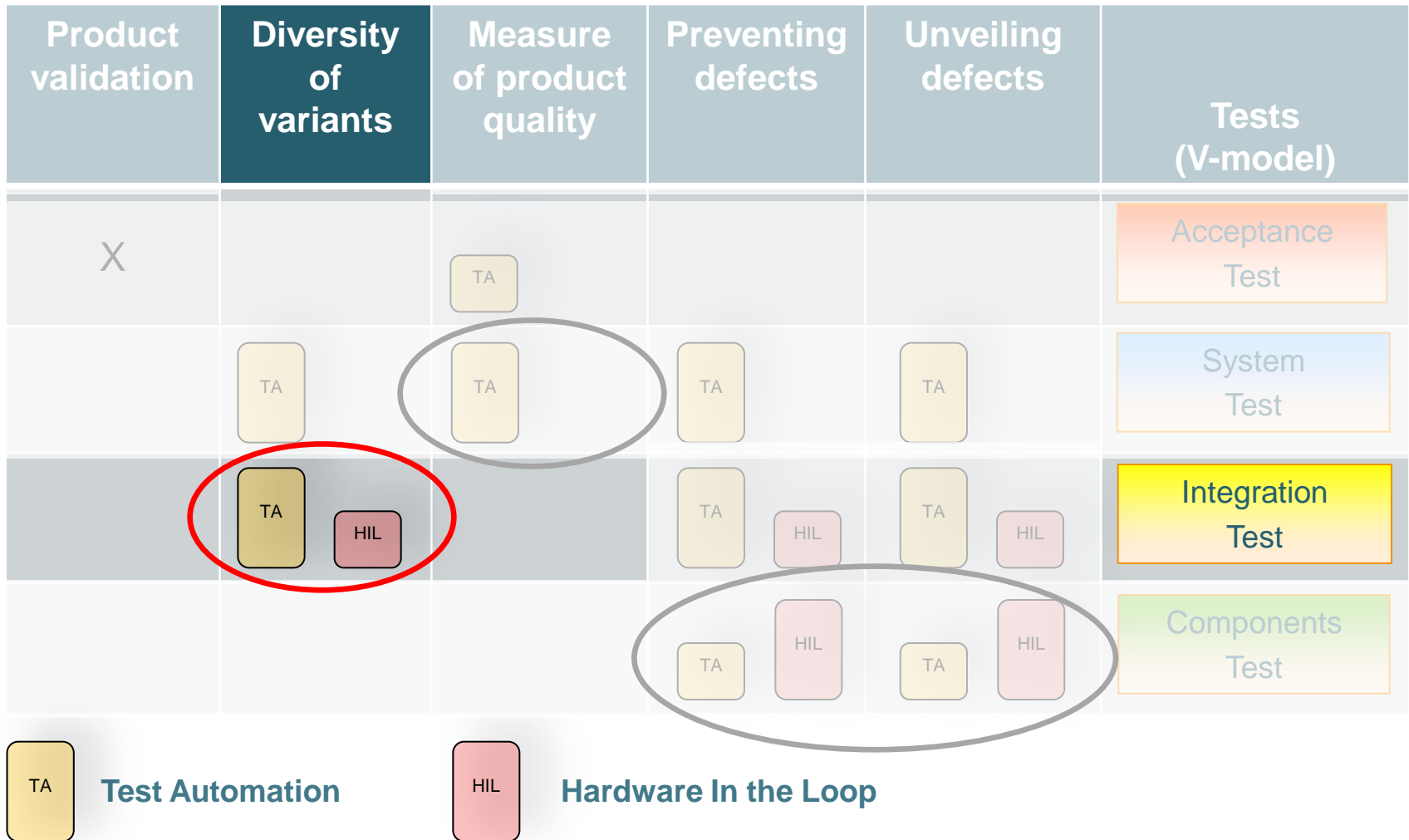

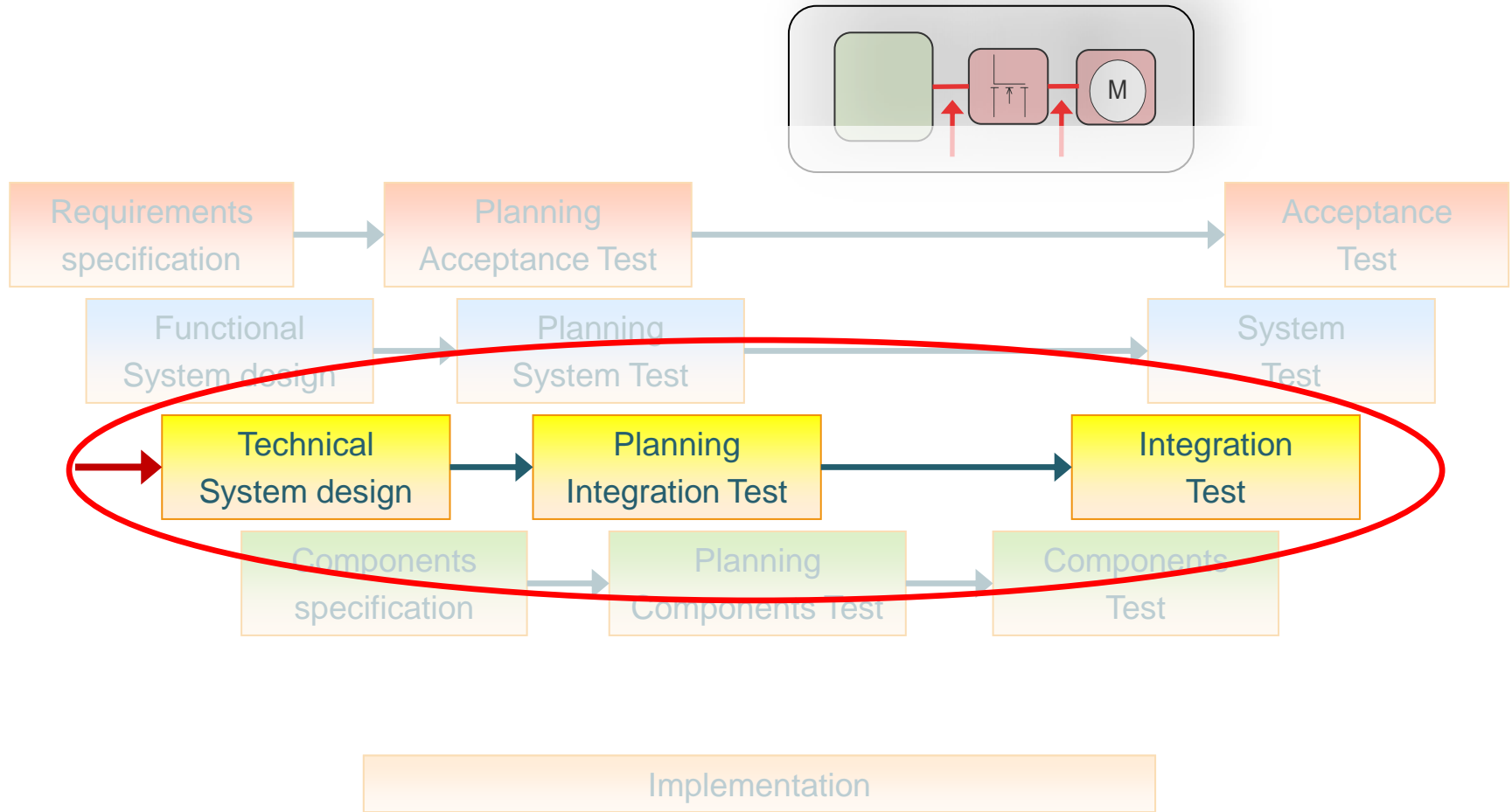

Example **variants test** :

- define parameter sets for test case set

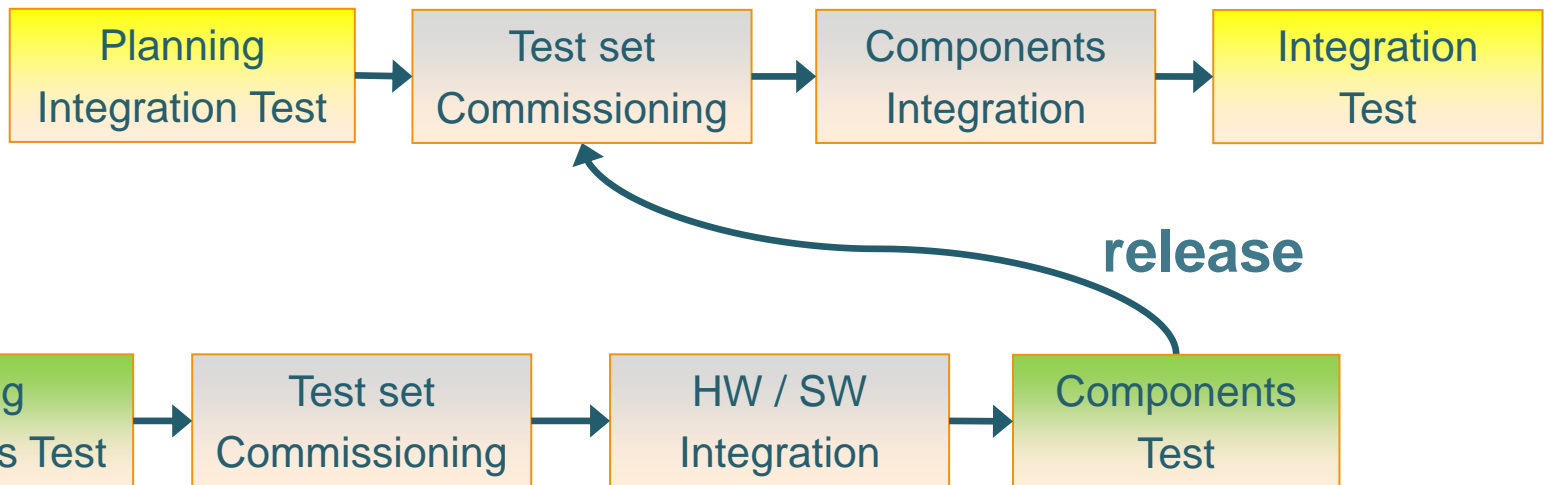
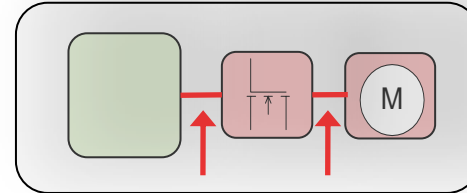

HIL → early variants testing



TA → fast coordination of variants tests

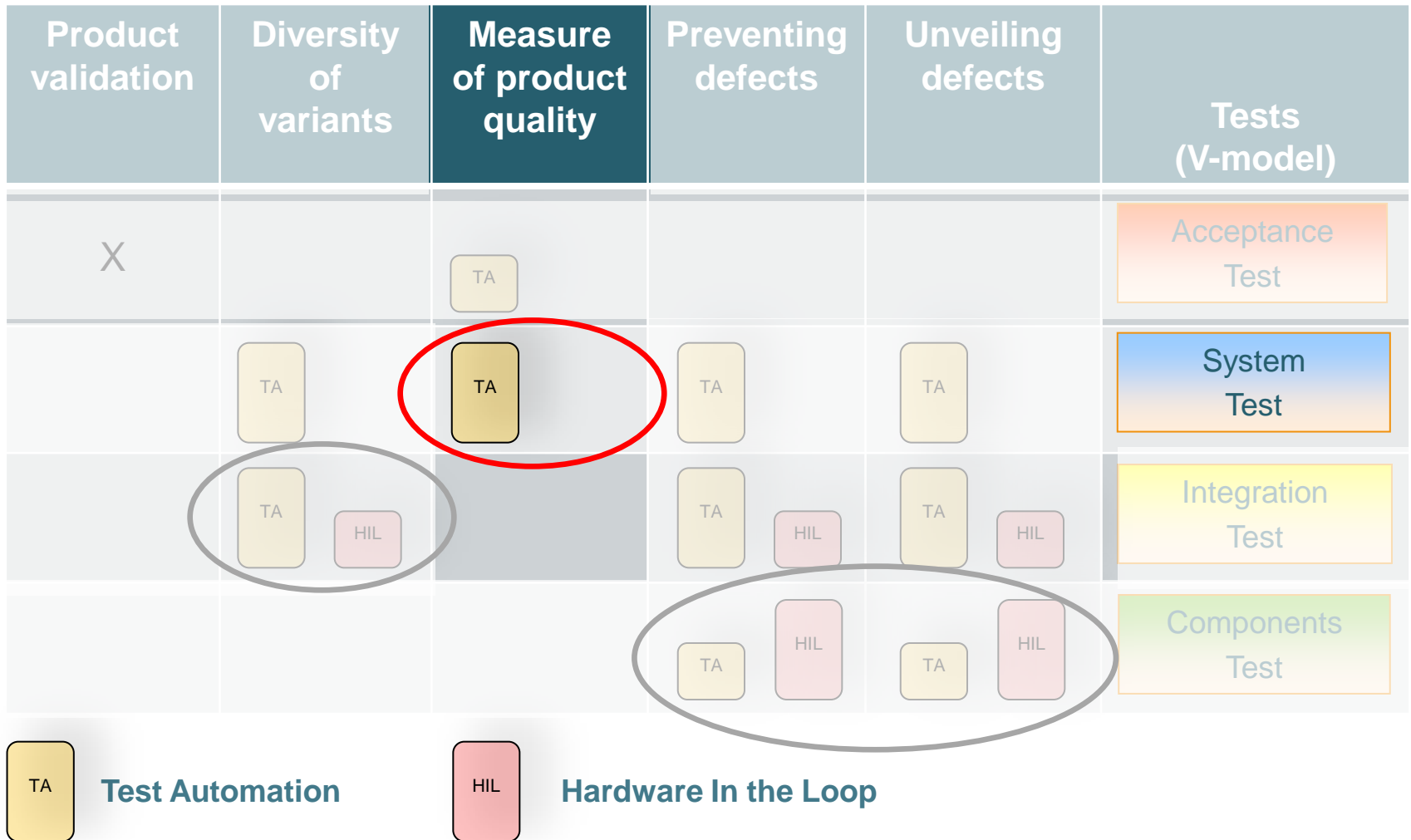

■ V-Modell

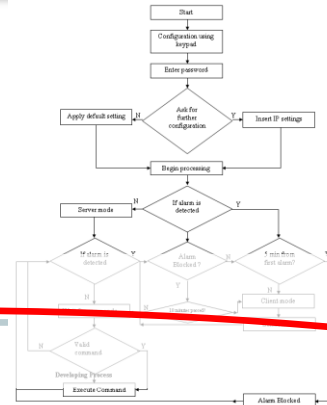
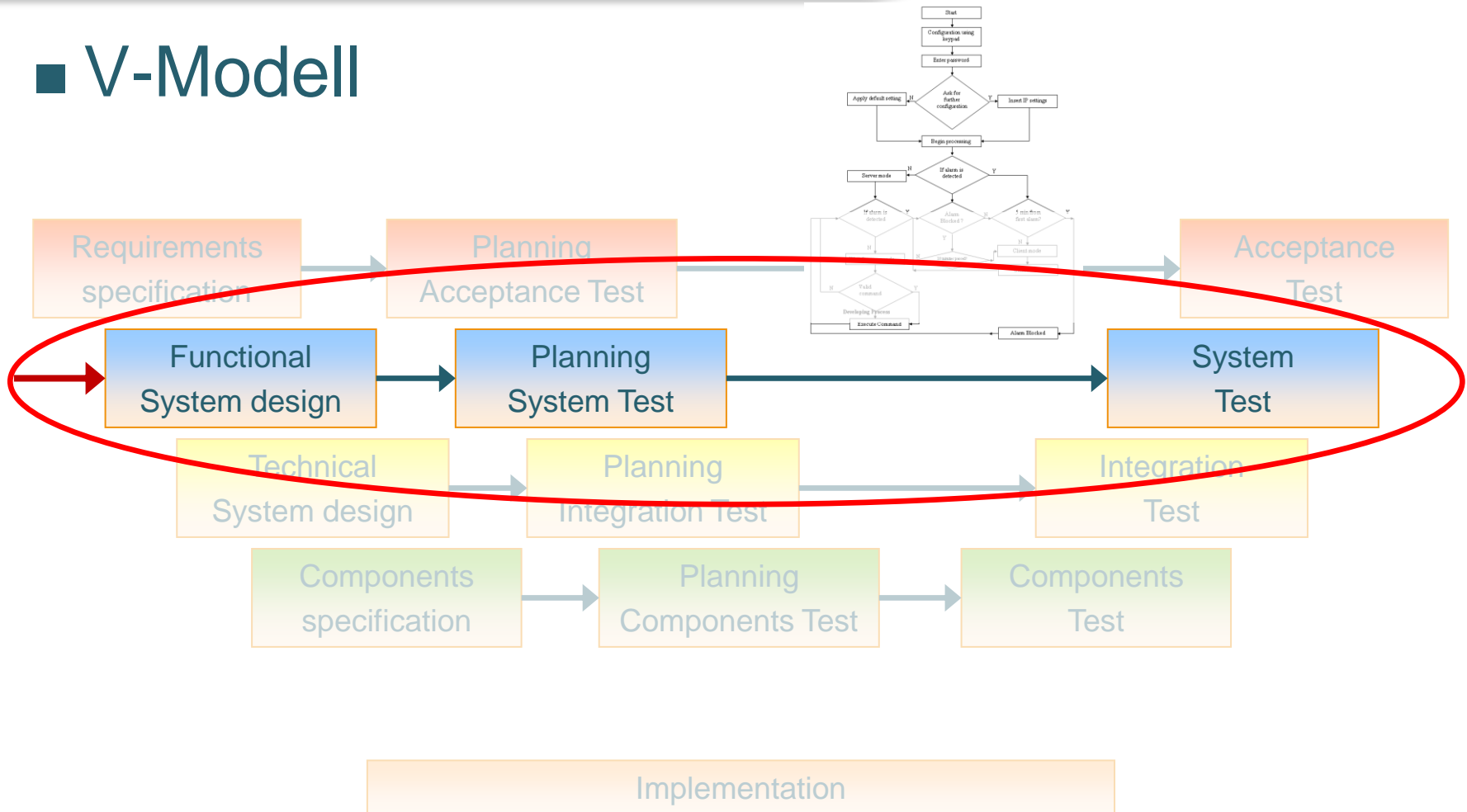

Example **stress test** :

- define tests according to system boundaries

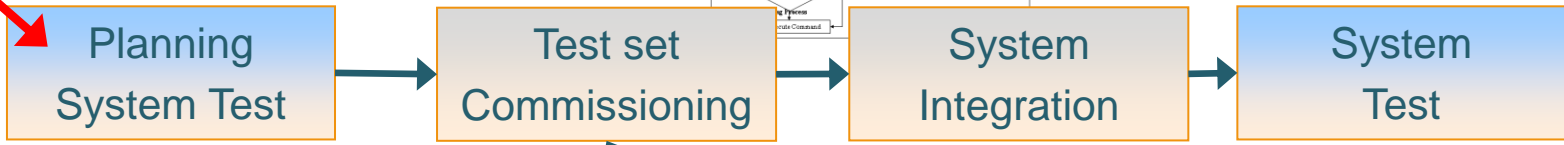

TA → significant quality information



HIL → used for early test development only

Improving Testing Productivity through the use of Test Automation

1 Testing as part of the development process

2 Test Automation equipment

3 Testing measures

4 Advantages Test Automation

Product Development with V-Model

TEST ING : example ressources

Product validation	Diversity of variants	Measure of product quality	Preventing defects	Unveiling defects	Tests (V-model)
X		TA			Acceptance Test
	TA	TA	TA	TA	System Test
	TA HIL		TA HIL	TA HIL	Integration Test
			TA HIL	TA HIL	Components Test



Test Automation



Hardware In the Loop

Advantages Test Automation	Tests (V-model)
	Acceptance Test
Significant quality information	System Test
Fast coordination of variants tests	Integration Test
Early defect tracking through first regression tests	Components Test

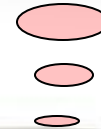
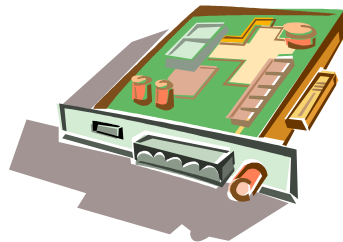
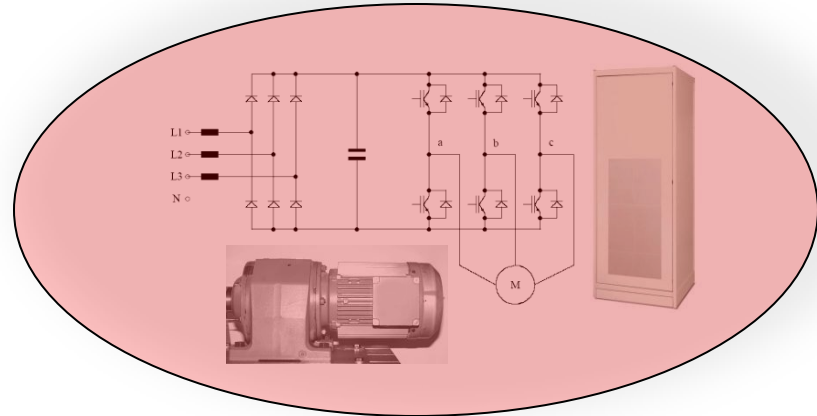

Your partner

- SOLIN AG

Our expertise

- system integration
- test automation
- test management

Our partner

- OPAL-RT

Thank you